

Super Max

Technical data:

Piston	4 oversizes available +.010, +.020, +.030, +.040"
Piston clearance	"KS" piston .002 - .0024" (0.05 - 0.06 mm) "Mahle" piston .0016 - .002" (0.04 - 0.05 mm)
Valve timing at .08" (2 mm) tappet clearance	intake open 2°b.TDC, closed 20°a.BDC exhaust open 36°b.BDC, closed 13°b.TDC
Valve clearance at cold engine	intake .002" (0.05 mm) exhaust .004" (0.10 mm)
Carburetor	Bing, Type AJ 2/26/25, main jet 105 idling jet 45, needle jet 2.68, needle position: while running in 2, thereafter 1, air screw 1½ turns open, mixing chamber insert 5. up to .008" (0.2 mm)
End float on transmission shafts	6 V generator, battery ignition
Electrical equipment299" (7.6 mm) or 36° before TDC
Ignition timing016 - .020" (0.4 - 0.5 mm)
Breaker point gap	Bosch W 190 T 11 S or W 240 T 11
Spark plug028" (0.7 mm)
Spark plug gap	3½ pints (2 liters)
Oil tank capacity224" (5.7 mm) from the top of the slotted nuts to the clutch drum.
Clutch spring adjustment	

Dismantling of engine

When removing engine from frame do not remove hexagon head bolt on the rear of cylinder head until the engine is finally taken out. Otherwise it is possible for the engine to tip forward and damage the front mud guard. (Fig. M 01/1-9)

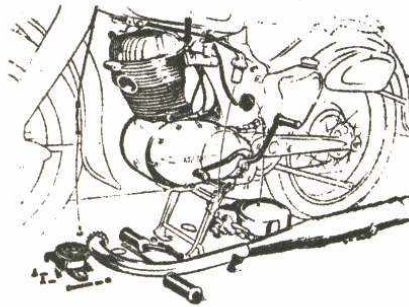

Fig. M 01/1-9

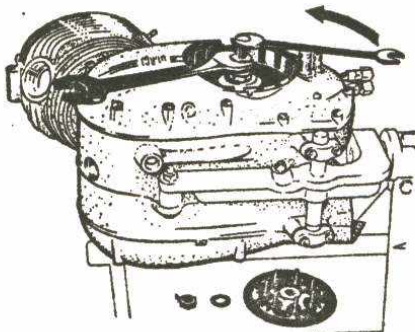

Fig. M 02/6a

For removal of the left hand side crank case cover the clutch drum #813 900 need not be removed. Only if clutch gear, clutch drum or part thereof has to be replaced removal becomes necessary. Use puller #103 647. (Fig. M 02/7)

TO AVOID ERRORS WHEN
ORDERING PARTS, GIVE
MAKE, YEAR, MODEL ALSO
ENGINE & SERIAL NUMBERS

Turn the engine so that the right side is on top.
Note: Two 5-mm (0.20-in) dia. balls and two thrust rods will drop out.

8. **Remove the automatic timing control.**
 To do this the screw must be unscrewed completely.

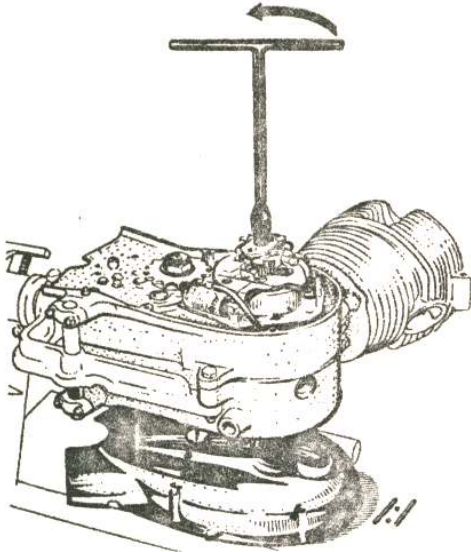

Fig. M 02/8

Push back the dynamo brushes, and hold by means of the spring (to assist reassembly). Remove the bolts in the dynamo housing.

9. **Remove armature.**
 Place one of the clutch thrust rods in the armature bore, and screw up the bolt holding the armature. This will force the armature off its shaft. Remove the key.

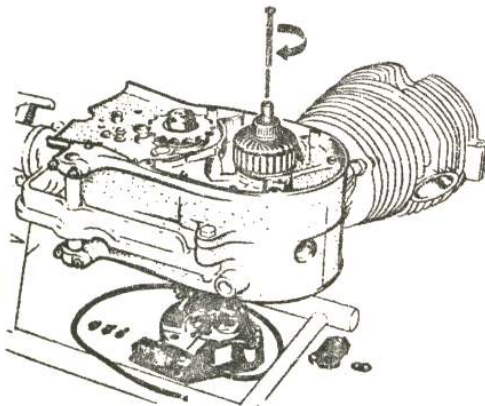

Fig. M 02/9

10. **Remove balance weight.**
 Stand the engine upright. Turn the crank until the balance weight points downwards, and loosen the nut on the camshaft spindle. Hold

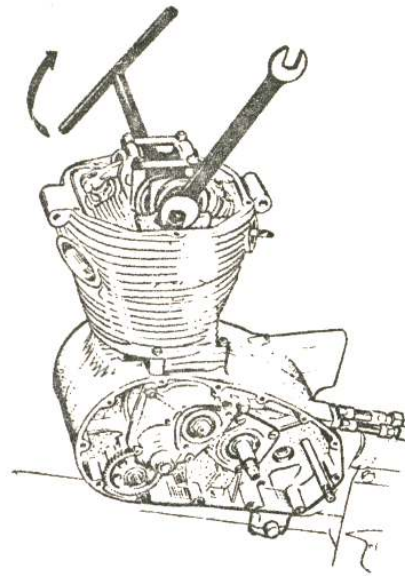

Fig. M 02/10

the nut by means of a 19-mm spanner and turn the spindle by means of a box spanner. Lay the engine sideways, so that the nut and spring washer do not fall into the crankcase when they come clear. Turn the crankshaft until the balance weight points upwards. Remove the balance weight.

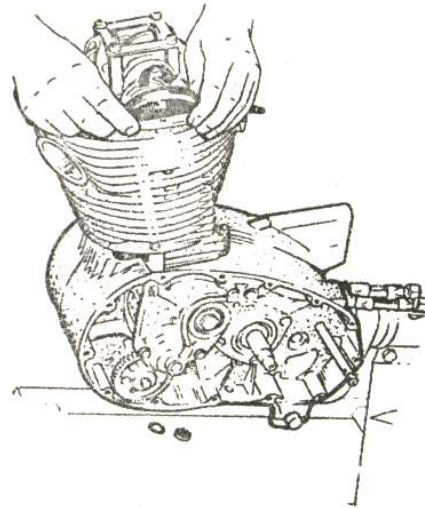

Fig. M 02/10 a

11. **Remove driving pin and camshaft spindle.**
 Stand the engine upright, and turn the crankshaft until the two connecting rods for the eccentric drive are on their **top dead centre**. Pull out the driving pin and knock out the camshaft spindle.

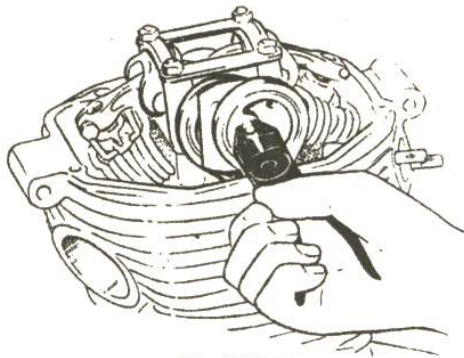

Fig. M 02/11

Press the tie rod away from the camshaft housing, and push it sideways.

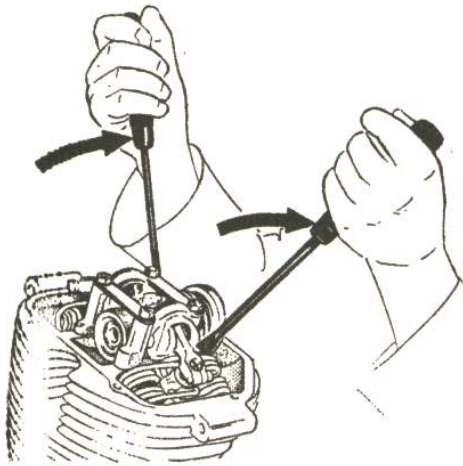

Fig. M 02/11a

12. Remove the camshaft housing

Remove the nuts and lock washers from the bearing brackets, and take off the bearing bracket straps. Slide two screwdrivers or levers under the rocker arms and force up to remove the camshaft housing.

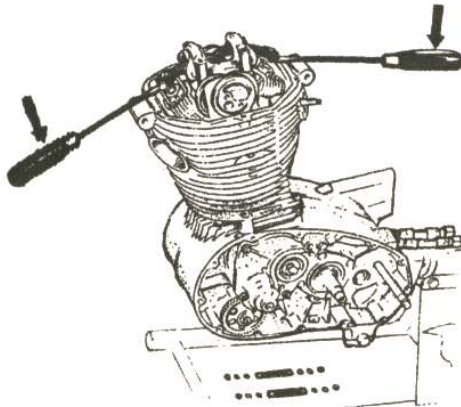

Fig. M 02/12

(Take care not to damage or lose the rubber ring on the bearing bracket (inlet side) or the shims).

13. Remove upper eccentric disc

Mark the front side of the eccentric. Push the tie rod into the groove cast into the cylinder head, press the front connecting rod off the eccentric disc and to the left, and push the rear connecting rod with the upper eccentric disc to the right.

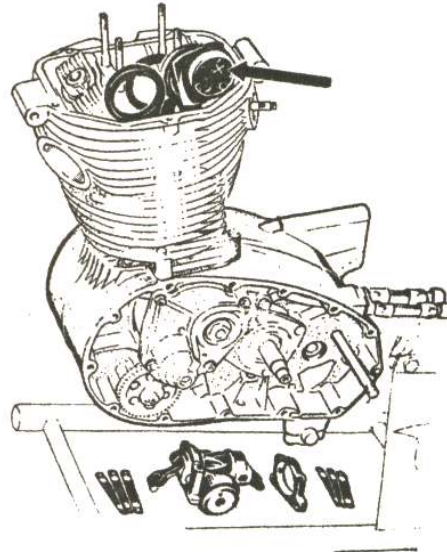

Fig. M 02/13

Turn and withdraw the eccentric disc.

14. Remove cylinder head.

Remove the M 6 nut on the cylinder head, and unscrew four nuts (left-hand thread) on the cylinder flange.

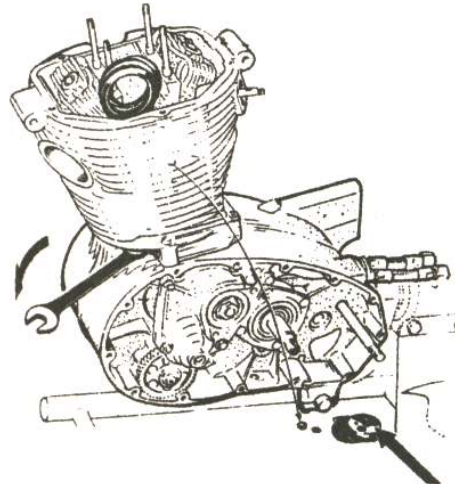

Fig. M 02/14

Remove the cylinder head and gasket.

see "Motorcycling Engineering" p 213, 311

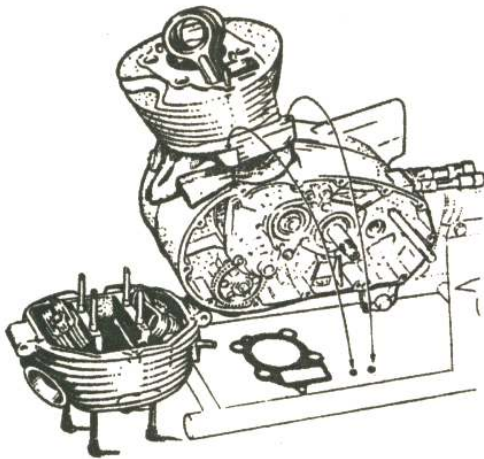

Fig. M 02/14a

15. Remove cylinder.

Unscrew two M 6 nuts on the cylinder flange. (Cover the crankcase with a rag to keep out dirt).

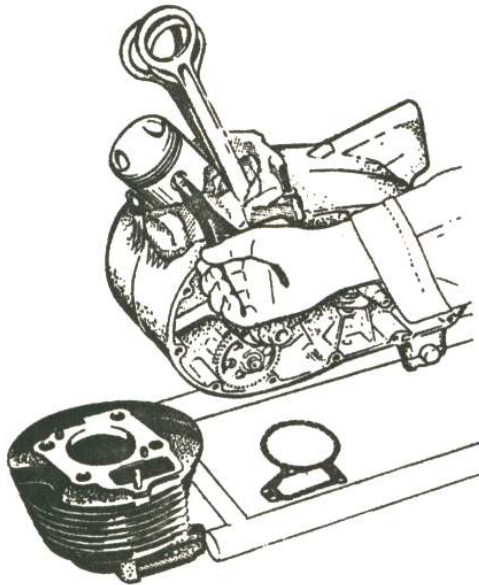

Fig. M 02/15

16. Remove piston.

Remove the circlips. Heat the piston until the gudgeon pin can be pushed out using the gudgeon pin extractor (088 891 908).

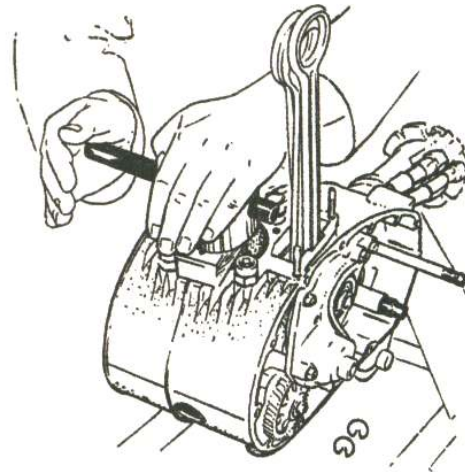

Fig. M 02/16

17. Remove Front Bearing Plate.

Turn the engine so that the left-hand side is on top.

Standard: Unscrew four nuts and one bolt on the bearing plate and one nut and lock washer on the lower eccentric shaft.

Special: Unscrew three nuts and one bolt on the bearing plate and one collar bolt on the lower eccentric shaft.

Support the connecting rod by means of a slotted piece of wood.

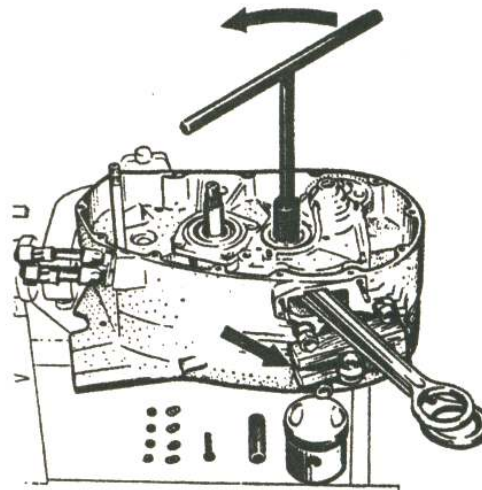

Fig. M 02/17

Attach jig (088 891 900), with the extractor spindle removed to avoid damaging the sealing disc on the bearing plate.

Screw the three M 8 bolts on the fixture up evenly, and the bearing plate will lift off.

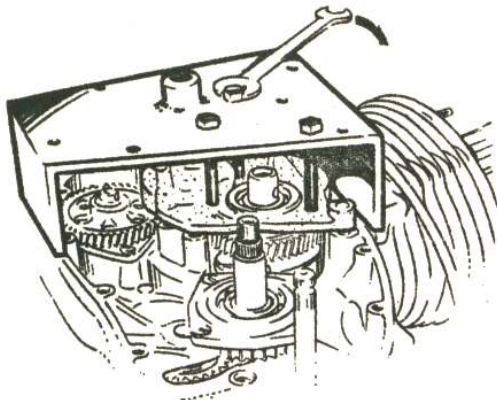

Fig. M 02/17a

18. Remove Left-Hand Crankshaft Bearing

Remove the nut and lock washer, and remove the ball bearing using withdrawing tool (088 891 917) and spacer bush (088 891 914). Note that there are spacers fitted on the crankshaft under the bearing.

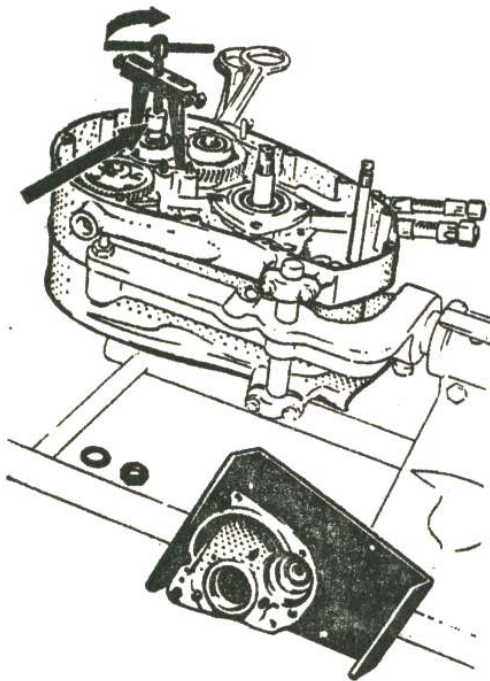

Fig. M 02/18

19. Remove Oil Pump.

Remove the nut for the oil pump, two lock washers, the carrier plate, and the driving pinion. Unscrew three cheese-head screws on the

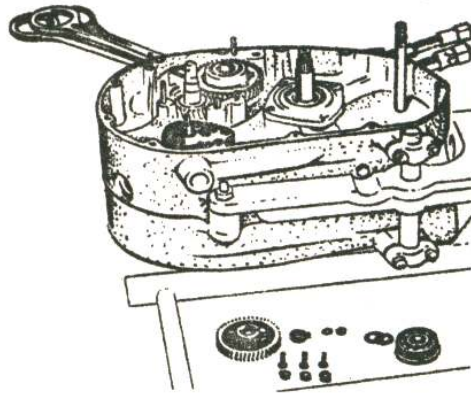

Fig. M 02/19

oil pump, replace the driving pinion, screw the nut on lightly, and then force out the oil pump using two levers or strong screwdrivers.

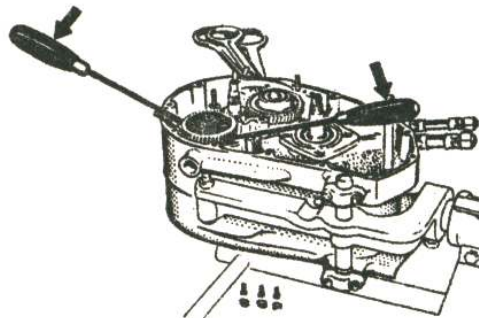

Fig. M 02/19a

20. Remove lower timing gear

Force off the bearing on the intermediate gear. (There may be shims under the bearing).

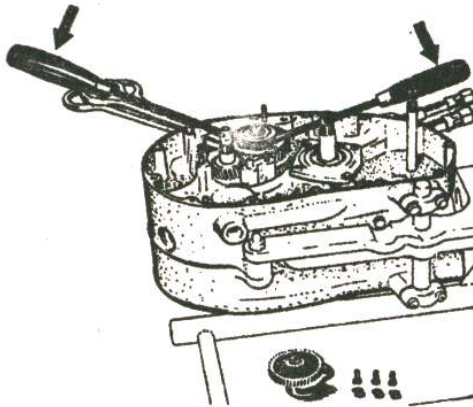

Fig. M 02/20

Remove the intermediate gear with the driving pin, the front eccentric connecting rod, and the lower eccentric complete with the connecting rod attached to it.

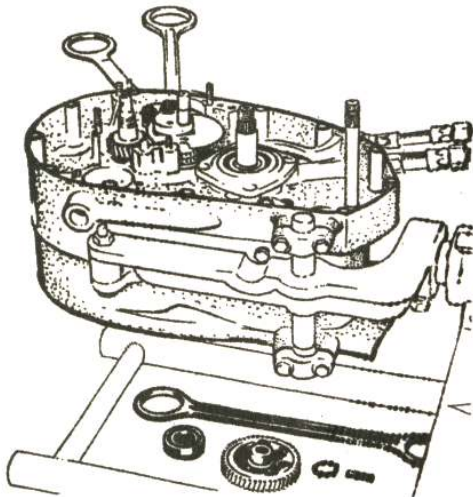

Fig. M 02/20a

The tie rod remains on the bearing bush.

21. Remove driving pinion.

Place the spacer bush (088 891 914) on the left-hand crankshaft stub, and remove the driving pinion with the aid of withdrawing tool (088 891 917).

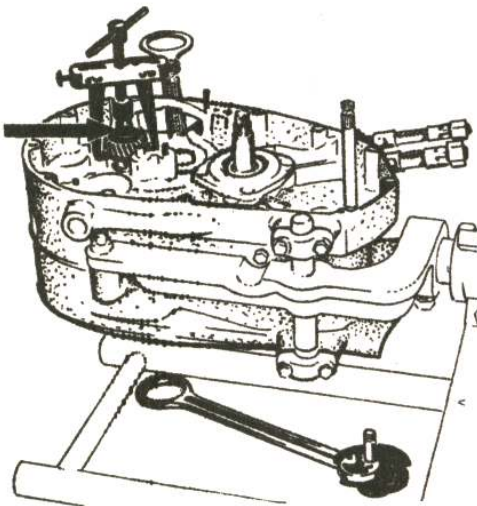

Fig. M 02/21

Turn the crankshaft and remove any burr on the collar of the left-hand crankshaft stub by means of a flat scraper, in order to avoid driving and damaging the bearing bush when removing the crankshaft.

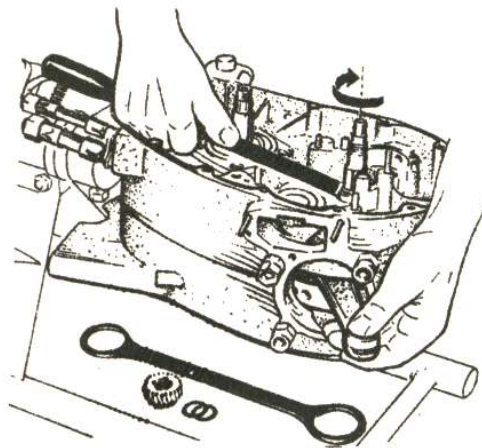

Fig. M 02/21a

22. Checking ball bearings on driving shaft.

Turn the engine so that the right-hand side is on top. Unscrew the nut (with a sealing ring or seal ring pressed in) on the chain sprocket. Hold by means of a length of chain secured to the pin on the assembly stand jig (pin is supplied with the fixture). Turning the driving shaft to and fro will indicate whether the bearing is in good condition.

23. Unscrew sludge traps.

Turn the crankshaft until one of the sludge traps can be seen through the front tapped hole on the left-hand half of the crankcase. Screw in the special screwdriver (038 891 918) and unscrew the sludge traps. An M 6 thread is tapped in the head of the sludge traps so that they can be completely withdrawn using a 6-mm bolt. Remove the second sludge trap in the same way. When the crankshaft is removed from the engine the sludge traps can be unscrewed using a 12-mm (1/2-in) wide screwdriver.

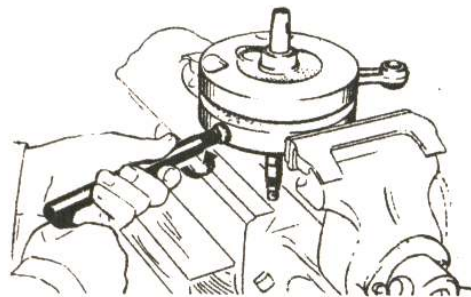

Fig. M 02/23

24. Dismantling Crankcase.

Unscrew four M 6 nuts and five M 7 nuts, each with two lock washers, and three countersunk bolts from the right-hand half of the crankcase. Remove the bolt holding the crankcase to assembly stand tig. Lift off the right-hand crankcase half.

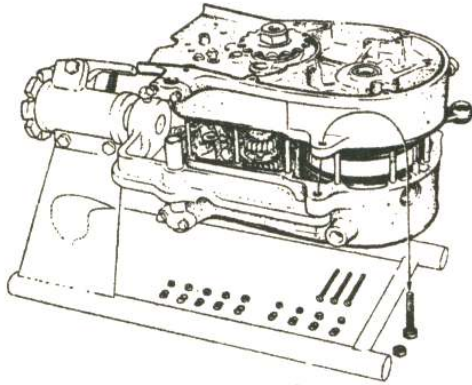

Fig. M 02/24

25. Remove Crankshaft and Gearbox Components.

Remove the crankshaft, if necessary the inner gear change spindle with spring and lever, all gear pinions, the mainshaft, the layshaft, and the complete selector drum. Also the gear pinion for bottom gear on the layshaft, together with its thrust washer, the kickstarter pinion with pawl and spring, the two thrust washers, and the gear-change spindle with the thrust washer.

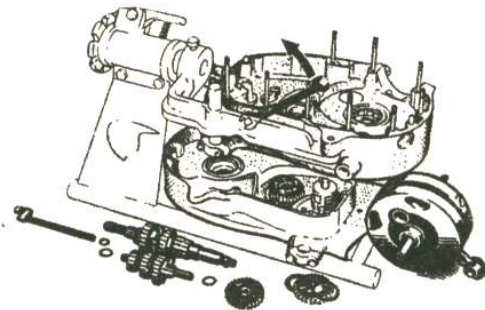

Fig. M 02/25

26. Remove Locking Pin.

Unscrew the hexagonal bolt, retaining spring loaded plunger complete with spring, lock washer, and washers, together with the strip spring for the selector drum.

27. Unscrew both nuts on the clamp for the lower engine mounting, and remove the left-hand crankcase half from the assembly stand tig.

28. Unscrew the cheese-head bolt from the two oil pipes. Remove the oil pipes with seals and rings, and the locking plate.

29. Remove Eccentric Pin and Selector Quadrant

On the right-hand crankcase half unscrew the M 8 nut on the eccentric pin; remove the lock washer, washer, seal, eccentric pin and ratchet plate, and the selector quadrant with the selector lever and the pawl housing. The driving shaft can remain in place provided that it and its ball bearing are in good condition (see section 22 for method of checking ball bearing). Take care not to damage the two needle bearings for the mainshaft.

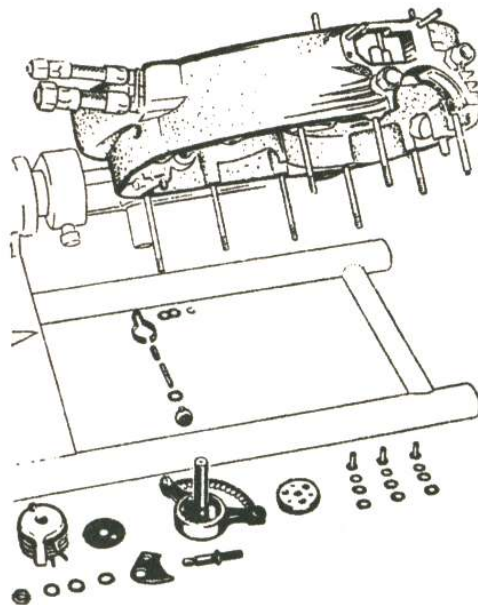

Fig. M 02/28

30. Clean and check all parts.

Assembly of Engine

(M 02)

31. Before fitting roller bearings, heat the crankcase. Then insert the bearing, and when the crankcase has cooled, tap the bearing lightly to make sure it is properly seated.

Note: Place the crankcase on a piece of wood to avoid damaging its surface.

32. Mount the left-hand half of the crankcase in the assembly stand rig, and hold it temporarily by tightening up the two nuts holding the clamp for the lower engine mounting.

33. Stick the crankcase gasket to the left-hand crankcase section with grease. There is no need to check the dimensions of the crankshaft and the crankcase. Since these are manufactured to give an **axial play of 0.3–0.6 mm (0.012–0.024 in)** (see section 45).

34. Adjust the strip spring for the selector drum

Place the spring on the crankcase, and pack it up with washers until it cannot be pulled up when it is fitted. Then remove the spring and washers.

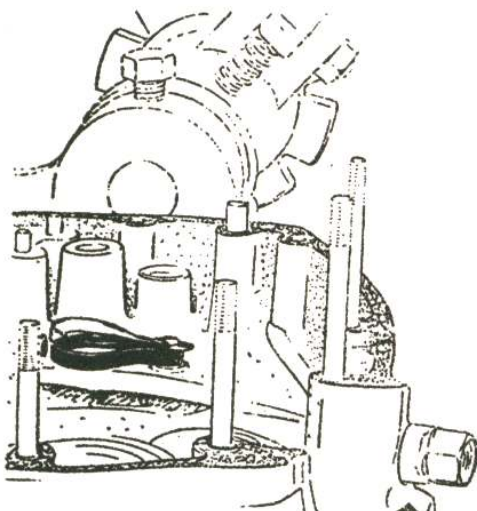

Fig. M 02/34

35. Fit crankshaft.

Clean the two plugs and screw them into the left-hand flywheel (see section 23). **Oil all moving parts.** Place the crankshaft in the left-hand crankcase.

36. Fit the gears

Place the washer for the kickstarter pinion (082 810 006, 1.2, 1.5, or 1.8 mm thick as required) with its wide bearing surface on the mainshaft ball bearing. Insert the pawl and spring in the kickstarter pinion. Place the complete pinion on its washer in such a way that the **smooth side is downwards.**

37. Grease the washer for the kickstarter pinion (072 710 036, with narrow bearing surface) and stick it to the lower pinion of the complete mainshaft. Push back the starter pawl against the kickstarter pinion with a narrow screwdriver, and carefully insert the mainshaft.

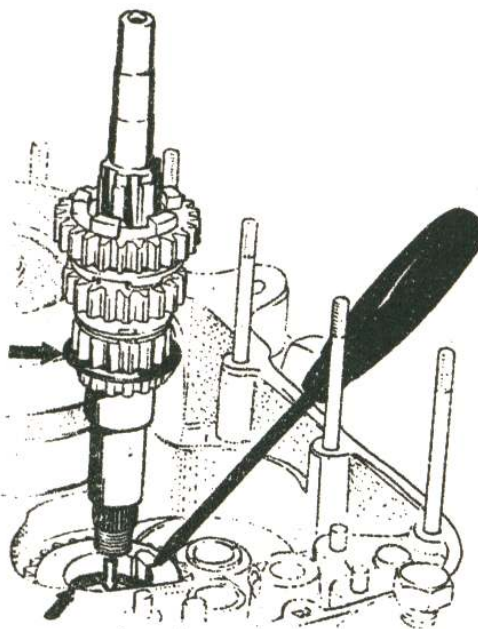

Fig. M 02/37

Hold the kickstarter pinion with the fingers, and turn the mainshaft clockwise. **A clicking sound must be heard.** When the mainshaft is turned anti-clockwise, it must turn the kickstarter pinion.

38. Then place the thrust washer (082 810 012) on the lower bush for the layshaft, and on it place gear pinion (072 710 506) (Bottom gear).

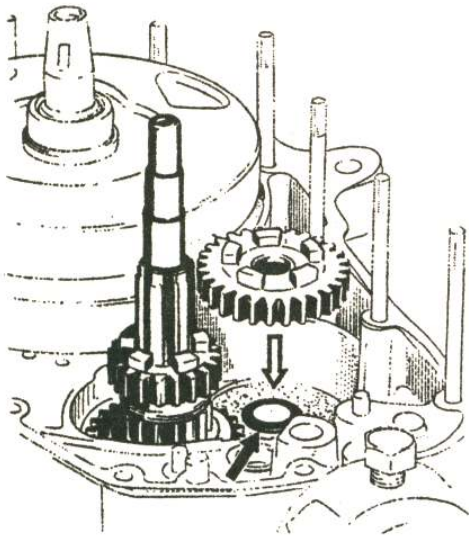

Fig. M 02/38

Place the strip spring on the collar of the selector drum.

Also place the layshaft sliding pinion (recognizable by the groove for the thrust ring) on the lower striker fork so that the **chamfered dogs point upwards**. Place the mainshaft sliding pinion on the upper striker fork so that the **chamfered dogs point downwards**. Now fit the whole assembly so that the sliding pinion on the upper fork slides on the mainshaft and the end of the selector drum enters the bush and the eye of the strip spring. The lower fork with the layshaft pinion remains free.

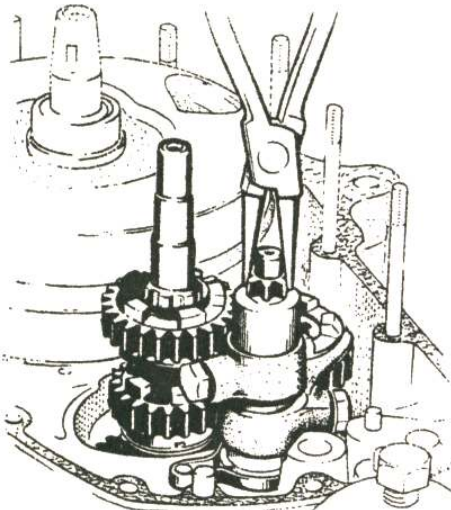

Fig. M 02/38 a

39. Insert the layshaft (long spigot downwards).

Note: Do not displace the thrust washer for the layshaft. Fit the washers for the strip spring and secure with clip. Insert the plunger and spring in its bush. Coat the locking bolt with sealing compound and screw it in. **Engage neutral gear:** Turn the selector drum to the **right**



as far as it will go, at the same time moving the layshaft (Bottom gear). Then turn the selector drum back one notch (neutral) since the right-hand crankcase half can be fitted only when neutral gear is engaged. (See Fig. and sketch). Place pinion (072 710 009) on the layshaft with its dogs pointing towards the sliding pinion. Also place the small pinion (082 810 011) on the layshaft with the higher collar pointing downwards. A thrust washer (082 810 012) must be placed on this pinion, and the ring must be placed on the mainshaft. Finally place the two small needle bearings on the mainshaft and insert the gear-change spindle to which the gear-change link is attached, together with its washer. Place the gear-change link, so that the hole (a) in the link lines up with the hole (b) for the inner gear-change spindle and the 6-mm pin (c).

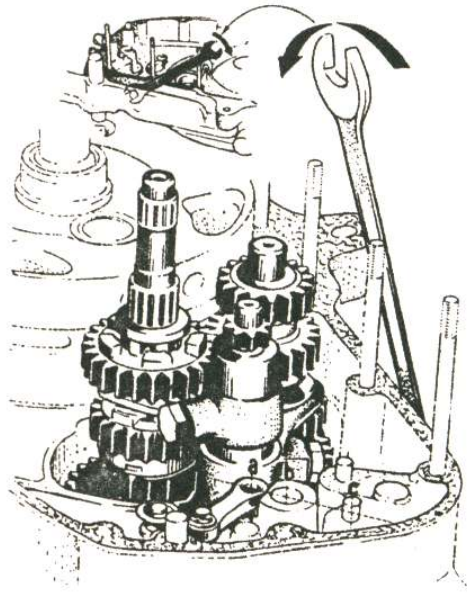

Fig. M 02/39

40. **Fit Gear-Change Mechanism.**

If it has been removed, re-attach the selector lever to the quadrant. The quadrant should be attached in such a way that the mark "0" stamped on it is visible from above. The pawl housing, with two springs, pawls, and pins, is placed on the selector arm, and the whole is fitted to the selector-drum bearing. Adjust the

pawls (see Fig. M 02/40). Fit the releasing plate and the eccentric pin for the fine adjustment of the gear change mechanism. Attach seal, washer, and lock washer. Lightly tighten up nut.

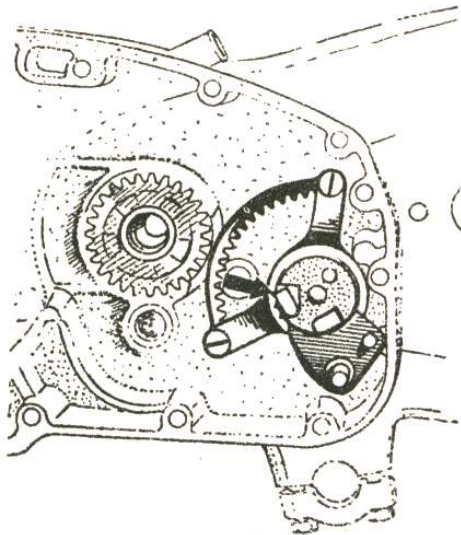

Fig. M 02/40

Then place the washer (072 714 010) on the pawl housing, and insert the inner gear-change spindle (072 714 023).

41. Set Selector Quadrant to Neutral

On the opposite side of the crankcase half remove the M 6x4 hexagon bolt. Adjust the selector quadrant so that the final gap between the teeth lines up with the hole for this bolt when the pawl has disengaged. File the end of an M 6 bolt about 35 mm (1 3/8 in) long to a point, and screw it in (see Fig. M 02/41). **The point must reach into the final gap between the teeth at the right-hand end of the quadrant to such an extent that there is about 0.5 mm (0.02 in) play between the end of the bolt and the quadrant.**

The mark "0" stamped into the quadrant will then point to the centre of the selector-drum bush (neutral position). Allowing a certain amount of play between the point of the bolt and the quadrant as described above has the advantage that the toothed quadrant and the pinion on the selector drum can then more easily be mated together. Assemble the inner gear-change lever, the sleeve, and the return spring in such a way that the ground ends of the spring bear against the gear-change lever. Then push the assembly onto the inner gear-change spindle so that the ground ends of the spring come to bear against the eccentric pin. When the assembled inner gear-change lever

has been placed on the spindle, press lightly against the lever and at the same time disengage the pawls and turn it slightly clockwise. The gear-change lever will then adopt the correct position with respect to the pawl housing (neutral).

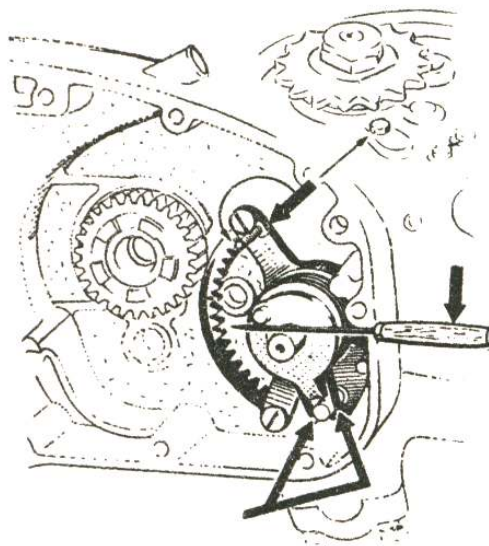

Fig. M 02/41

42. Attach the Right-Hand Crankcase Half.

Grease the mating surface, and place the right-hand half on the left-hand half. Make certain that the spindle on the inner gear-change lever enters the hole in the gear-change link on the gear-change spindle. Leave a gap of about 12 mm (1/2 in) between the two sections of the crankcase, and push the **gear-change spindle upwards**. Then push down the right-hand crankcase half with one hand, guiding the gear-change spindle with the other hand. If resistance is encountered as the crankcase halves come together, turn the driven shaft slightly. (To bring the teeth into engagement).

43. Check Gear-Change Mechanism.

Tighten up some of the nuts holding the crankcase sections together, and also the nuts and bolts of the assembly stand jig. Replace the pointed bolt by the normal M 6x4 bolt, smearing it with jointing compound before screwing it up. Stand the engine upright.

If the chain sprocket was removed, attach this to the driving shaft. Attach the locking plate and secure with a nut.

44. Check Gear Engagement.

Attach the foot-change pedal temporarily. Engage each gear in turn, and turn the chain sprocket. It must be possible to engage all the gears (rough adjustment). The fine adjustment of the gear-change mechanism (if this is necessary) is effected later.

45. Check Axial Play of Crankshaft.

Press the crankshaft to the left, and measure the distance between the end of the right-hand stub and the crankcase with a depth gauge. Push crankshaft to the right, and again measure this distance. The difference between the two measurements is the axial play. This should not be less than 0.3 mm (0.012 in) or more than 0.6 mm (0.024 in).

If the crankshaft play exceeds 0.6 mm (0.024 in), it will have to be removed from the engine. Place shims under the inner ring of the ball or roller bearing on the left-hand stub to bring the value of the play to 0.3 to 0.6 mm (0.012 to 0.024 in).

46. Check Connection Rod Alignment.

Push the inspection pin, (088 891 906) into the little-end bush, and turn the crankshaft until the pin bears against the flange of the crankcase. Check that the pin bears evenly on the flange on either side. If not, line up the connecting rod.

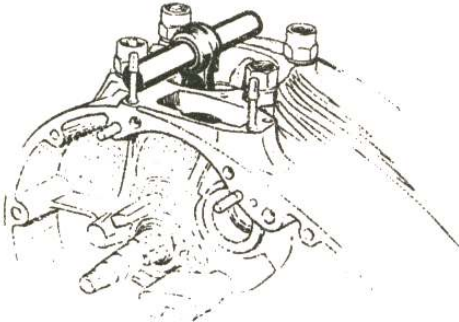

Fig. M 02/46

Screw up and tighten all nuts and bolts. Turn the engine so that the left-hand side is on top.

47. Fitting Pinion on Crankshaft.

Turn the crankshaft so that the crank is at TDC, when the upper of the four feathers on the left-hand stub gives the exact setting. On the pinion a setting mark is stamped directly over one of the splines. When the pinion is placed on the shaft, this spline must mate with the top feather.

There is another mark stamped on the pinion, four teeth to the right of this mark, not counting the tooth immediately over the spline. This is used for setting the intermediate gear.

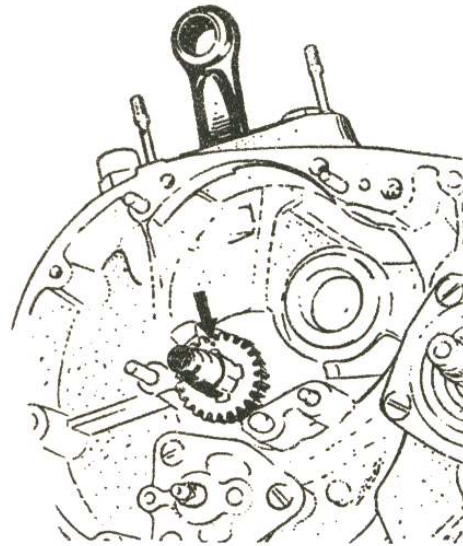

Fig. M 02/47

The pinion is forced on the shaft using the bush (088 891 921) and a nut and spring washer.

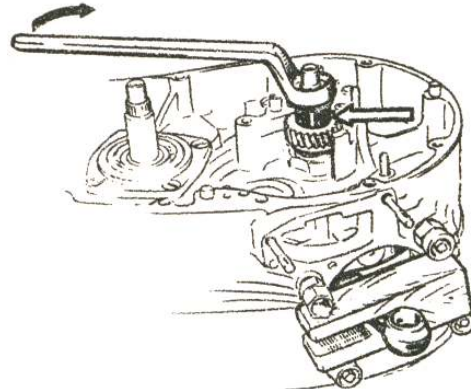

Fig. M 02/47a

48. Centralising the crankshaft and pinion.

Use jig (088 891 900) to press the crankshaft over to the left, placing a piece of steel or some other suitable packing on the righthand crankshaft stub. Measure the distance between the crankcase and the pinion. To this dimension add one half the axial play of the crankshaft. This gives the thickness of the shims which will have to be fitted on final assembly. Since the pinion, the shims, the ball bearing, and the lock washer are screwed tightly together by means of the nut, there will be an axial play

of about 0.15 to 0.30 mm (0.006 to 0.012 in) between the crankshaft and the bearing on either side. Remove jig (088 891 900).

49. Fitting the oil pump.

Place two new rubber rings on the sleeves. Place the complete oil pump in the crankcase and secure with three cheese-head bolts, each with two lock washers. Attach the oil-pump driving pinion, place the carrier plate in position on the spindle, and secure with a nut and two lock washers. If necessary use a slotted piece of wood to support the connecting rod.

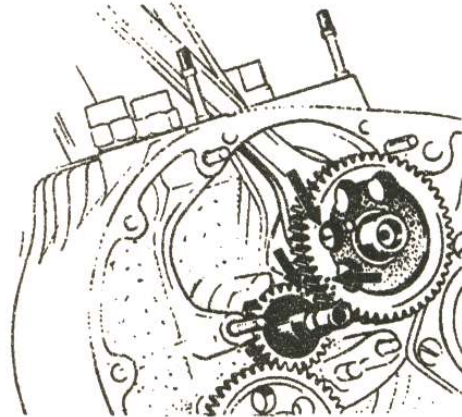

Fig. M 02/50 a

50. Fit the lower eccentric shaft.

If the tie rod was removed, replace this with the chamfered edge of the hole pointing towards the crankshaft. Fit the lower eccentric shaft complete with eccentric rod and needle bearings in the eccentric shaft bearing bush, and fit the front eccentric rod. **Attach both the eccentric rods with the word "innen" (Stamped on the rod) facing the crankshaft.**

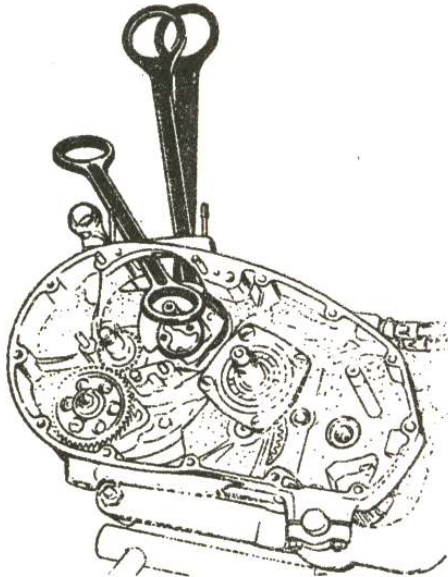

Fig. M 02/50

Fit the intermediate gear (note the setting marks on the 8th and 9th teeth to the left of the hole for the driving pin), and turn the crankshaft until the two holes for the driving pin are in line. Then insert the driving pin.

51. Position the intermediate gear.

To do this measure the distance between the crankcase and the collar of the intermediate

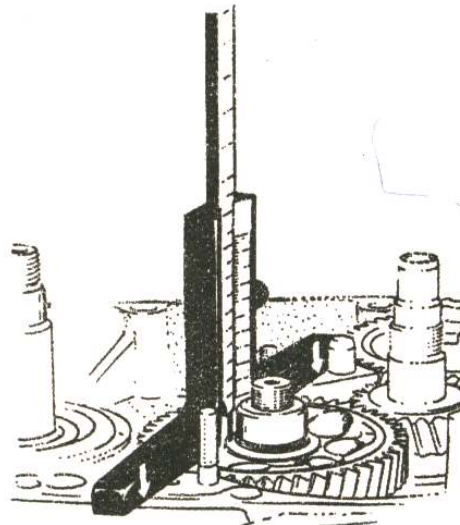

Fig. M 02/51

gear and the distance from the ball bearing in the bearing plate and the mounting flange on the plate. (First tap the bearing lightly to make sure that it is firmly seated).

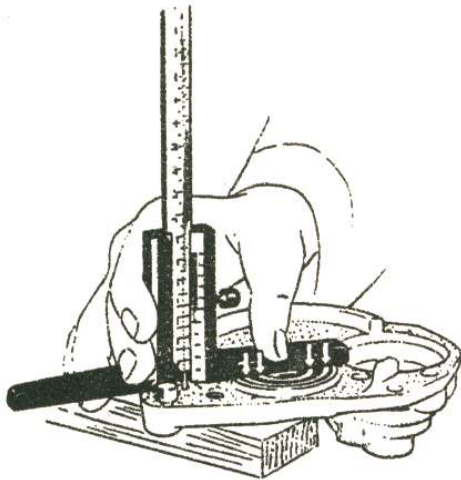

Fig. M 02/51 a

Fit shims so as to reduce the difference between these two readings to about 0.2 mm (0.008 in.).

52. Attach bearing plate.

Place spacer washers on the pinion. Place the ball bearing on the left-hand crankshaft stub, fit a lock washer, and tighten up the nut. Use a slotted piece of wood to support the connecting rod. **The lip on the seal ring in the bearing plate must point towards the crankcase.** Hit the bearing plate lightly with a hammer to make sure that it seats properly. Place a lock washer on the eccentric shaft, and tighten up the nut. Turn the engine so that the right-hand side is on top.

53. Fit the electrical installation.

Fit the Woodruff key for the armature, slip the armature on, and attach the casing with the ignition lead. Lightly tighten up three cheese-head bolts, with lock washers and plain washers. Attach the automatic timing control and secure it. Place the dynamo brushes on the commutator. Turn the engine so that it is upright.

54. Fit the piston and cylinder.

Fit a circlip in the piston. Heat the piston, and use the gudgeon pin extractor (088 891 908) to push the gudgeon pin into the piston. The piston is the right way round when the arrow points to the front of the engine. Fit the second circlip, covering the hole for the cylinder in the crankcase while doing so. Push the piston down on to the slotted piece of wood supporting the connecting rod. Stick the cylinder base gasket on the cylinder flange. Carefully compress the piston rings with the special pliers (088 891 901), and slide the cylinder over the piston. Remove the special pliers and the piece of slotted wood. Tighten up the cylinder-head bolts. Both cylinder-head sleeves must be in the top of the cylinder.



Fig. M 02/54

55. Timing Ignition.

Place the piston at TDC. Adjust the gap at the contact-breaker points to 0.4 mm (0.016 in.).

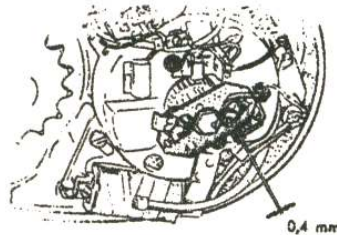

Fig. M 02/55

Time the ignition so that, with the fly-weights fully extended (the weight **without** a stop is the one by which the timing should be adjusted), ignition occurs when the piston is .6 mm before TDC.

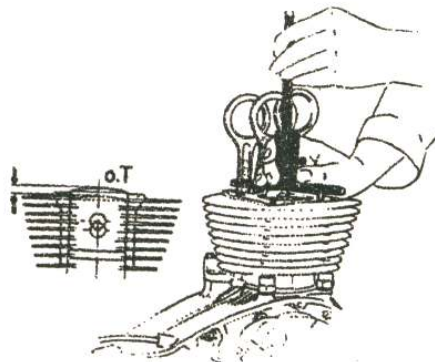

Fig. M 02/55 a

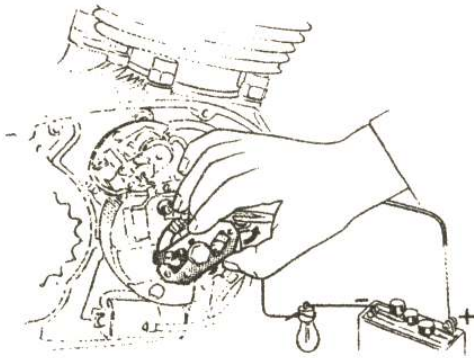

Fig. M 02/55 b

For timing the ignition exactly, use a battery and a bulb which lights up at the point of ignition. Connect the battery and lamp up in the following way: 1 lead containing the lamp from battery + ve terminal to terminal 15 on the dynamo, the other lead from battery - ve terminal to crankcase (earth).

When the crankshaft is turned in the normal direction of rotation of the engine, the lamp will light up at the moment ignition takes place. Note that it is the instant at which the lamp first lights up which is required.

If this test shows that the ignition timing requires adjustment (for it to occur at 7.6 mm before TDC), the dynamo housing will have to be turned. If the ignition is too far advanced, turn the housing in the direction of rotation of the engine, while if the ignition is too far retarded, turn the housing in the opposite direction. Then secure the dynamo.

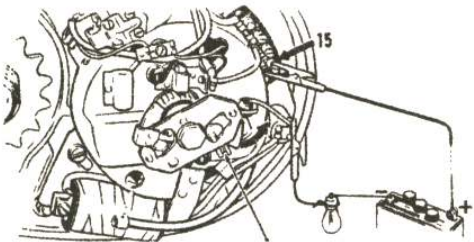

Fig. M 02/55 c

Another method of timing the ignition is to use a piece of very thin fibre-less paper, which is placed between the contacts and which can just be withdrawn without damage at the moment when ignition occurs.

56. Fit the cylinder head.

Apply the cylinder-head gasket. Fit the cylinder head, and then screw up the M 6 nut using washer. Screw up the nut with the double hexagon a couple of turns first, and then tighten up the other three nuts alternately (left-hand thread).

57. Fit Eccentric Drive.

Turn the engine so that both eccentric rods are at TDC.

Thoroughly oil the bushes. Push the tie rod in the groove provided in the cylinder head, and fit the upper eccentric disc in the following manner: Pull the rear eccentric rod to the right and insert the eccentric disc (note the markings). Turn the eccentric disc anti-clockwise, and pull the rear eccentric rod slightly to the left. Continue turning the disc and at the same time push it into the front eccentric rod (do not use force).

58. Attach complete camshaft housing.

Place 0.4 mm (0.016 in) shims on left and right-hand sides of cylinder head, taking care that the oil channel in the cylinder head (inlet side) is not covered. Then fit the complete camshaft housing with the two bearing brackets and the rubber sealing ring.

Note! The cams on the camshaft must point downwards. Tilt the camshaft housing with the aid of a lever so that the tie rod can be slipped onto the collar of the bush. Fit and secure the two straps for the bearing brackets. Knock the tie rod right home using a copper or brass punch. Place eccentric assembly over camshaft and insert checking mandril (088 891 907) so that it projects evenly on either side over the machined surface on the cylinder head.

59. Lining up Camshaft Housing.

Measure the distance between the checking mandril and the machined surface on the cylinder head by means of a feeler gauge.

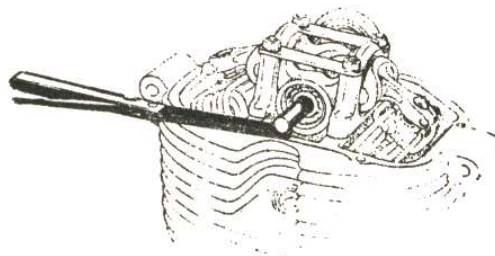

Fig. M 02/59

The distance should be the same on both sides, although that on the sparking-plug side can be up to 0.05 mm (0.002 in) less than the other. If the distance on the sparking-plug side is too large, shims will have to be removed, while if it is too small, extra shims will have to be added, the thickness of the shims amounting to about 1/3 the measured difference. Remove the setting pin and insert the pin for the camshaft from the right-hand side.

60. Attach Balance Weight.

Turn the engine until the holes for the driving pin in the eccentric disc and in the camshaft are in line. Insert the driving pin, and turn the crankshaft until the driving pin is at the bottom. Attach the balance weight, fit a lock washer, screw on the nut, and tighten up from both sides. Tighten up the nut in the manner described in section 10. Turn the crankshaft so that the balance weight is at the bottom.

61. Adjust Tappet Clearance.

Turn the crankshaft so that the piston is at TDC. Both valves must be closed. Adjust the tappet clearance, the values being inlet valve 0.05 mm (0.002 in) and exhaust valve 0.10 mm (0.004 in) with the engine cold. Tighten the pinch bolts. Fit the gasket and cover. (The cover is removed when the engine is fitted in the frame in order to check the oil circulation. Make certain that the balance weight is pointing downwards). Turn the engine so that the left-hand side is on top.

62. Fit the Pinion for the Clutch and the Complete Starter Shaft.

Make certain that the end of the spring is firmly held behind the lower rib in the crankcase.

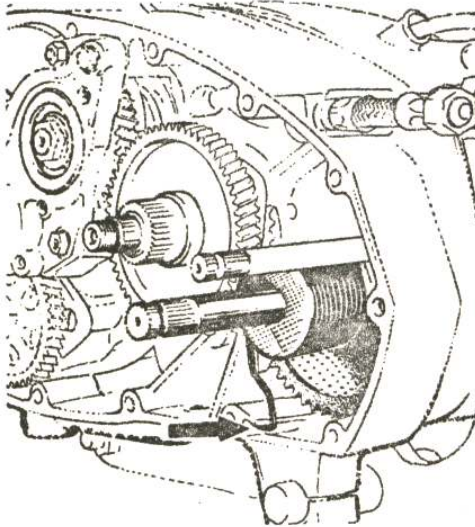

Fig. M 02/62

63. Fit the Left-Hand Crankcase Cover.

Stick on the gasket. Place guide bush (088 891 904) on the clutch pinion. Fit and secure the crankcase cover. Remove the guide bush.

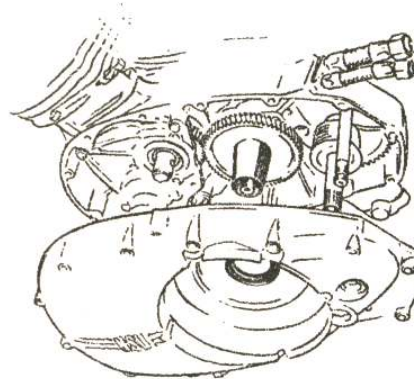

Fig. M 02/63

64. Fit the Clutch.

Place the outer clutch housing and the clutch body on the splined shaft, and secure (use holder 018 103 567). Then insert a lined clutch plate, followed by a steel clutch plate (the bent tabs must point upwards). Another lined plate is then inserted followed by a steel plate (without bent tabs). Then insert a lined plate and a steel plate (with the bent tabs pointing downwards). Finally insert another lined plate and the clutch trust rod. Insert the inner housing. Fit the spring boxes and springs and screw up the slotted nuts. Using the gauge (088 891 911) screw up the nuts until the distance between the top face of the nut and the inner housing is 5.7 mm. For the fine adjustment of the clutch see section 65.

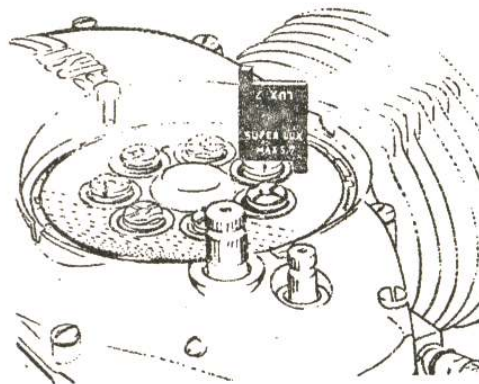

Fig. M 02/64

Screw in the two oil drain plugs and the plug with the magnetic insert. Turn the engine so that it is upright.

65. Checking the Gear-Change Mechanism.

Attach the gear-change pedal to the shaft, and engage the various gears while turning the chain sprocket. When changing up into 2nd and 3rd gear, and when changing down from 4th to 3rd and from 3rd to 2nd gears, it is essential that a distinct click be heard when the gear is engaged and the pedal is allowed to return slowly to its mid position. If the click is not heard the eccentric pin (fine adjustment) on the right-hand side of the crankcase must be turned one way or the other until the clicks are heard in the gears specified above. When the gear-change mechanism is correctly adjusted, tighten the hexagon nut on the eccentric pin by means of the special spanner (048 422 015) using a screwdriver to hold the pin. Remove the foot-change pedal.

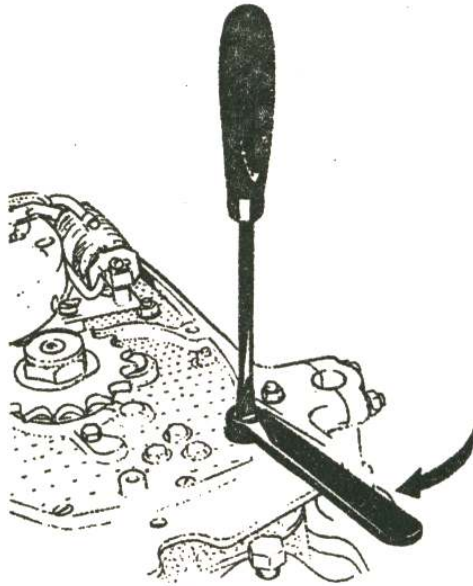

Fig. M 02/65

66. Fit the Right-Hand Crankcase Cover.

Turn the engine so that the right-hand side is on top. Fit two 5-mm dia. balls and the two thrust rods in the gearbox mainshaft in the following order: ball — rod — ball — rod. Attach the cover (first secure a 6-mm dia ball in the thrust spindle with grease), and secure with four bolts. Unscrew the plug on the right-hand cover and remove the thrust bolt and the hexagon nut. The fifth bolt for the cover is screwed into the thrust spindle of the clutch lever until the clutch is lifted about 1.5 to 2 mm (0.06 to 0.08 in). Turn the engine so that it is upright.

67. Checking Clutch Adjustment.

Attach the kickstarter crank. If the clutch ruts when the engine is turned over, the slotted nuts will have to be tightened up or slackened off. When the clutch is properly adjusted remove the bolt in the thrust spindle and screw it into the cover. Screw in the thrust bolt and a hexagon nut until the clutch lever has about 1.5 mm (0.06 in) play on the inside. Replace the plug. Remove the kickstarter crank.

68. Fit the Cover for the Clutch and Attach the Gear-Change Pedal and the Kickstarter Crank.

Turn the engine so that the left-hand side is on top. Fit and secure the clutch cover and also the gear-change pedal and the kickstarter crank. (Watch out for the teeth on the starter spindle). The gear-change pedal must be horizontal.

69. Turn the engine upright. Screw in the sparking plug. Attach the ignition lead and plug. Thread the rubber sleeve over the sparking plug. Fit the ring and seal to the oil inlet and outlet connections. Attach both oil pipes (the thicker in the rear hole); and secure with locking plate and bolt.

70. Loosen the clamps and remove the engine from the assembly stand.

MAX (Standard)

Wiring Diagram

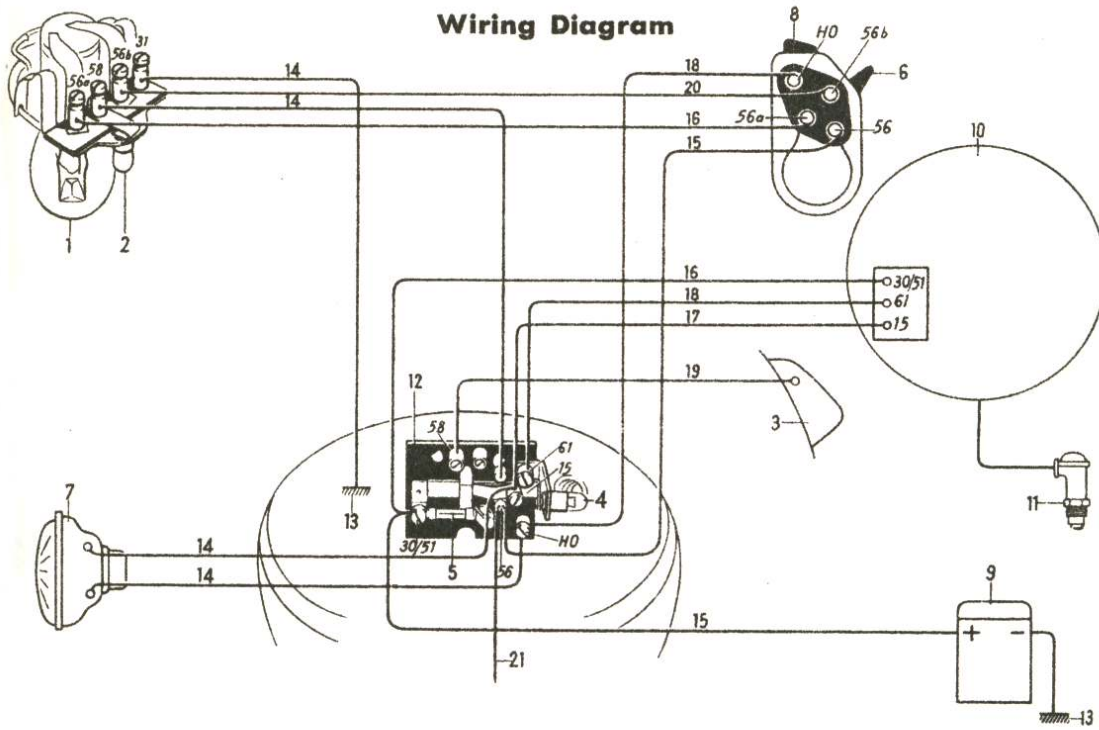

- | | |
|---------------------------|---------------------------------|
| 1 = Head Light Bulb | 12 = Base Plate |
| 2 = Parking Light Bulb | 13 = Earth |
| 3 = Rear Lamp | 14 = Black |
| 4 = Ignition Warning Lamp | 15 = White |
| 5 = Fuse | 16 = Red |
| 6 = Dip Switch | 17 = Yellow |
| 7 = Horn | 18 = Blue |
| 8 = Horn Button | 19 = Green |
| 9 = Battery | 20 = Grey |
| 10 = Generator | 21 = Cable to Speedometer Light |
| 11 = Spark Plug | |

Special and Super Max Wiring Diagram

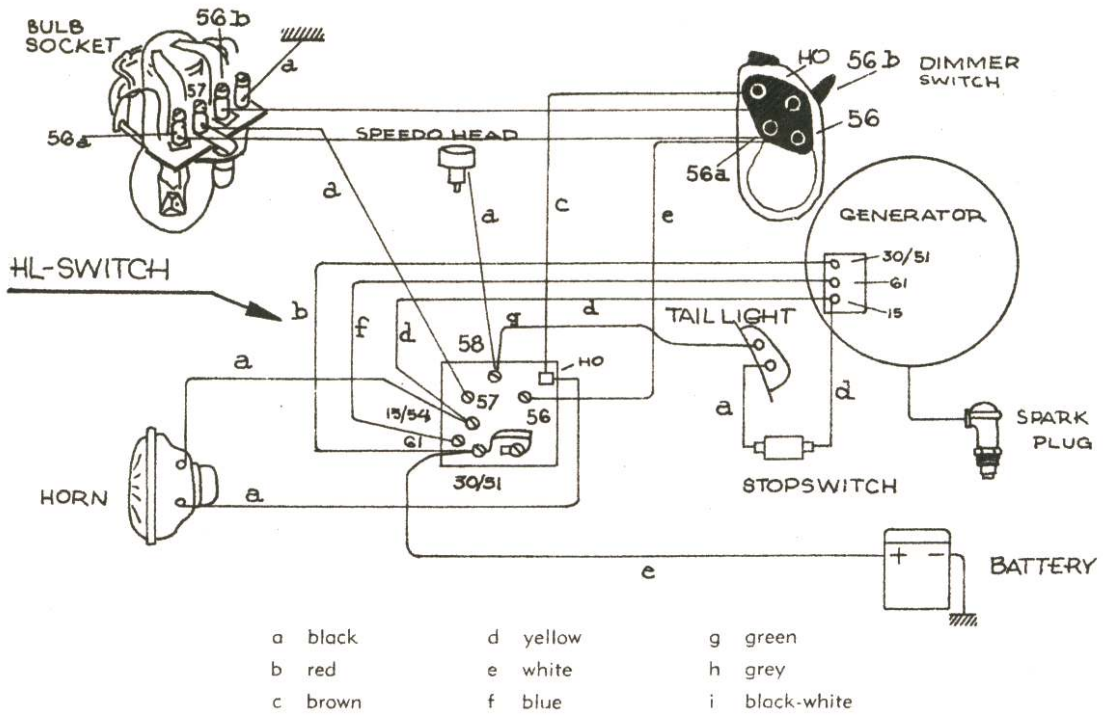

Super Max Wiring Diagram

